

(No Model.)

4 Sheets—Sheet 1.

J. B. HOWE.  
MACHINE FOR POUNCING HATS.

No. 480,098.

Patented Aug. 2, 1892.

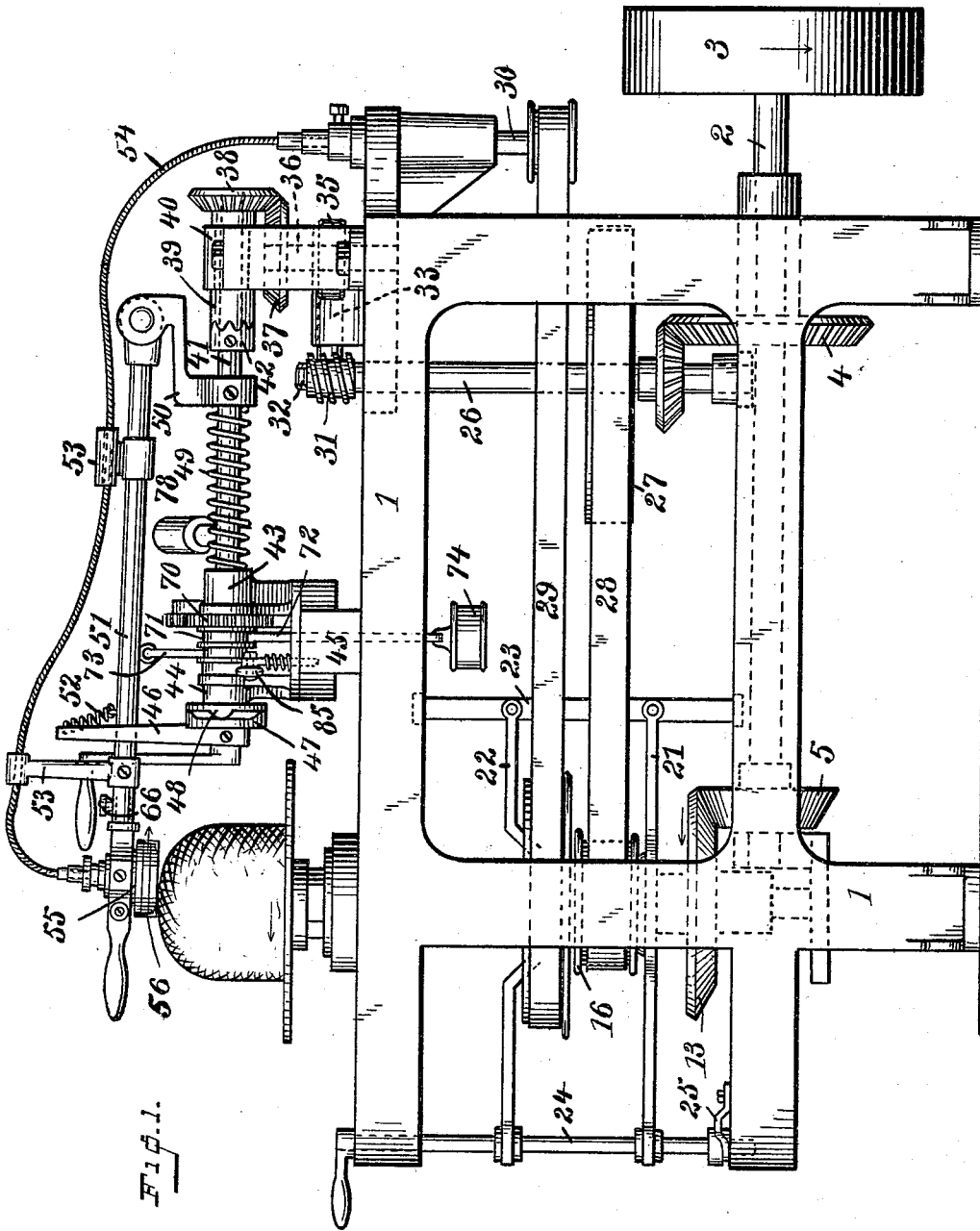

WITNESSES

*E. M. Newman,*  
*A. J. Tanner.*

INVENTOR

*John B. Howe*  
*by his attorney*  
*D. A. Hubbard*

J. B. HOWE.  
MACHINE FOR POUNCING HATS.

No. 480,098.

Patented Aug. 2, 1892.

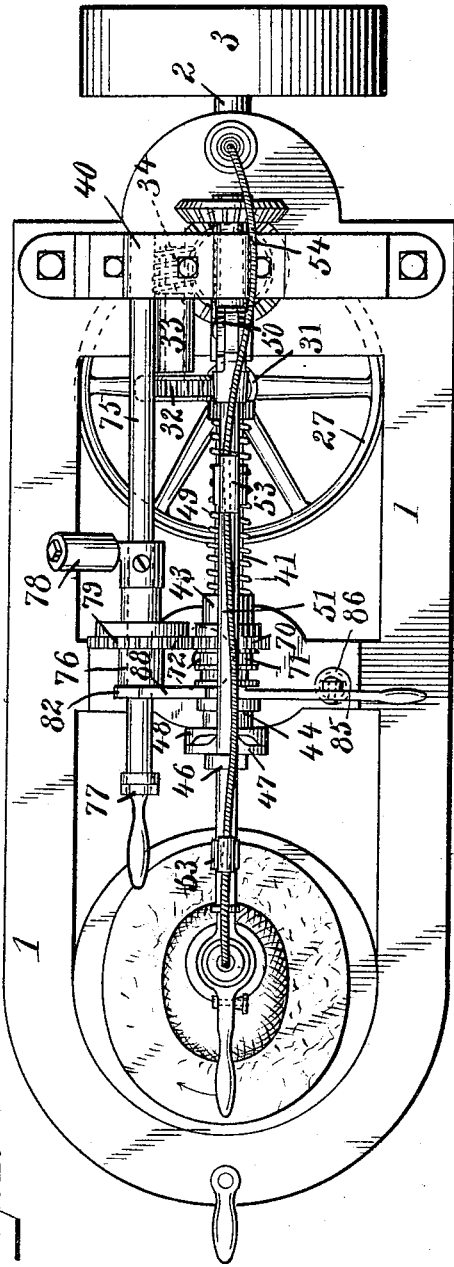

Fig. 2.

WITNESSES

C. M. Newman,  
A. J. Tanner.

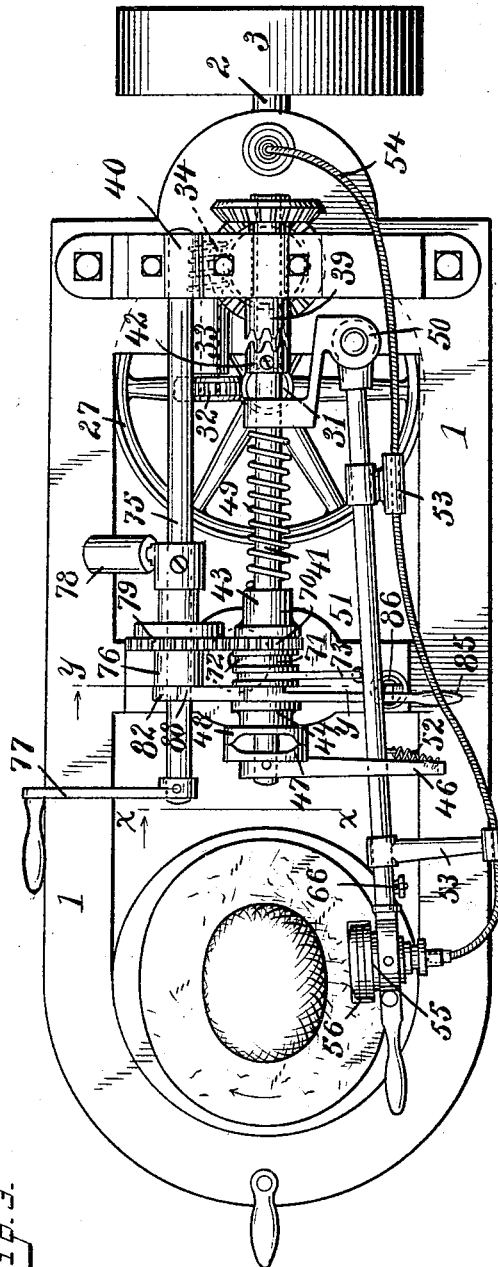

Fig. 3.

INVENTOR

John B. Howe  
by his attorney  
D. A. Hubbard

(No Model.)

4 Sheets—Sheet 3.

J. B. HOWE.  
MACHINE FOR POUNCING HATS.

No. 480,098.

Patented Aug. 2, 1892.

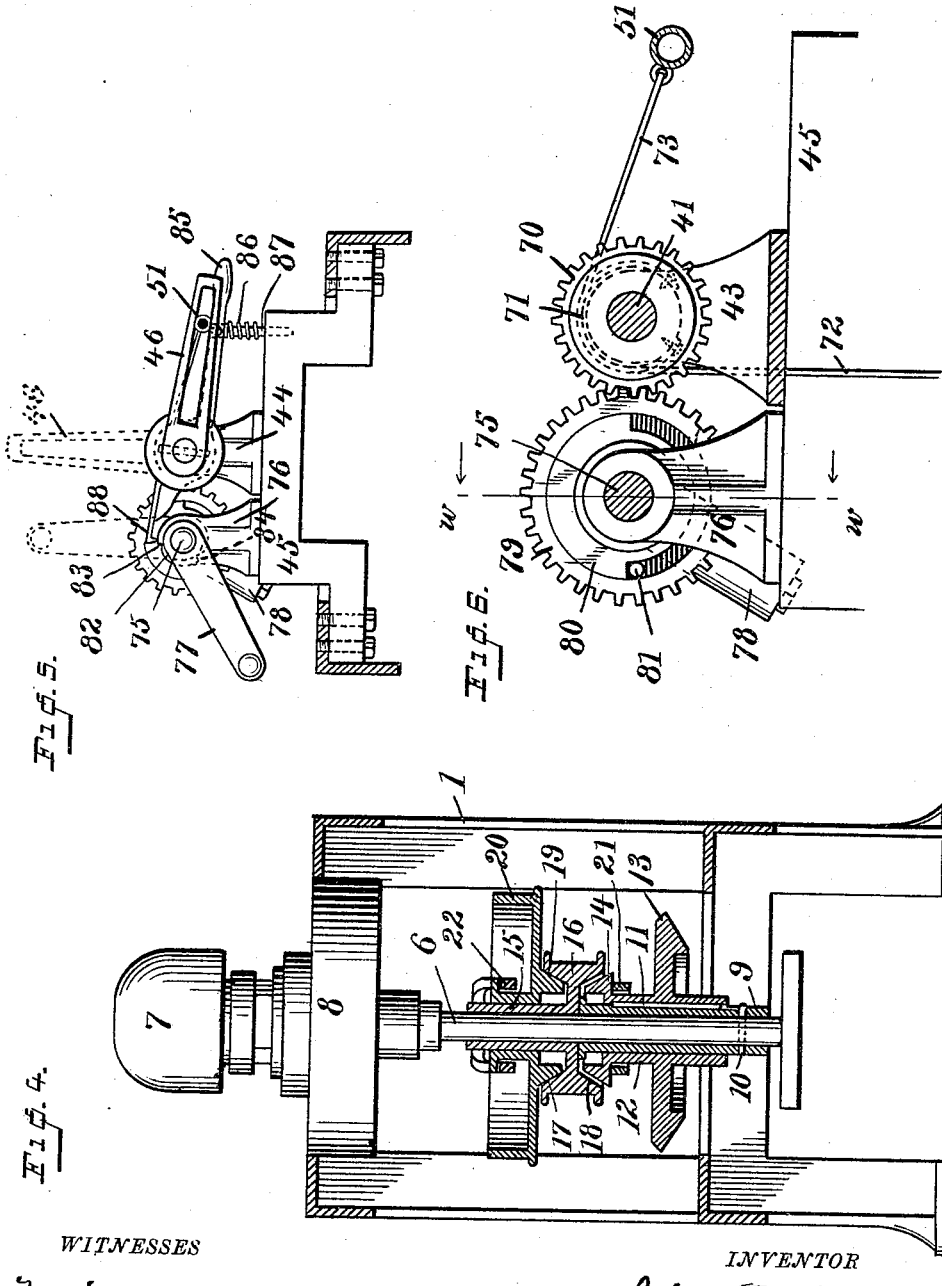

WITNESSES

*C. M. Newman,*  
*A. J. Tanner.*

INVENTOR

*John B. Howe*  
*by his attorney*  
*D. H. Hubbard*

J. B. HOWE.  
MACHINE FOR POUNCING HATS.

No 480,098.

Patented Aug. 2, 1892.

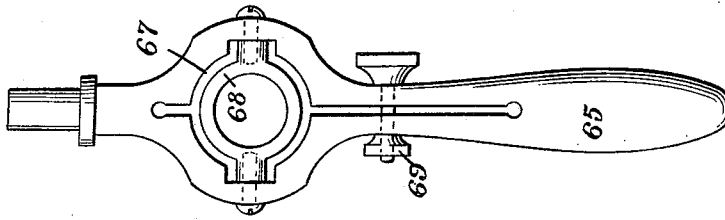

Fig. 10.

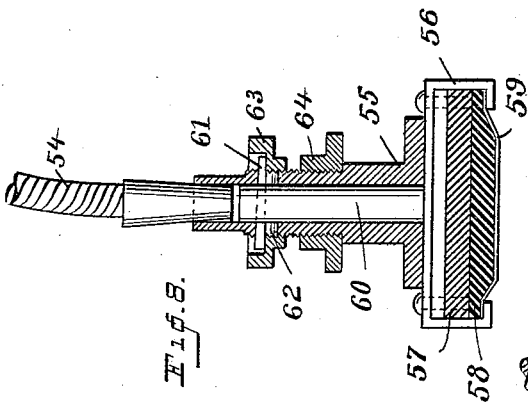

Fig. 8.

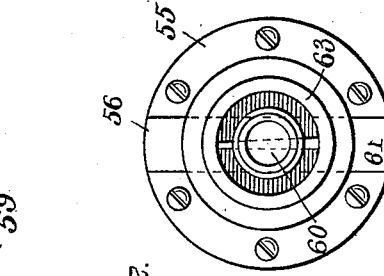

Fig. 12.

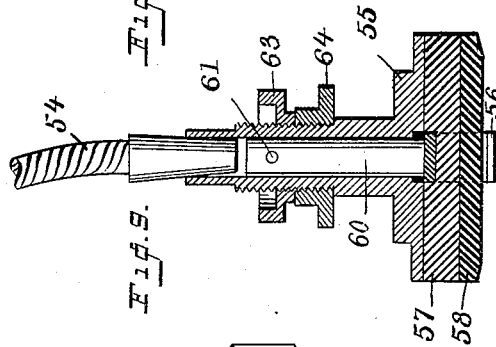

Fig. 9.

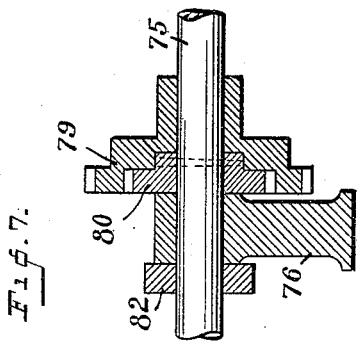

Fig. 7.

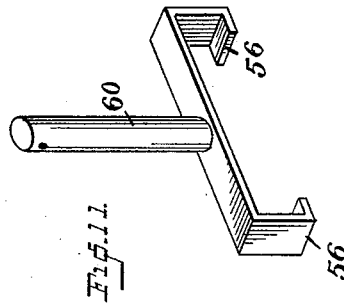

Fig. 11.

WITNESSES

*C. M. Newman,*  
*A. J. Tanner.*

INVENTOR

*John B. Howe*  
by his atty  
*O. A. Hubbard*

# UNITED STATES PATENT OFFICE.

JOHN B. HOWE, OF DANBURY, CONNECTICUT.

## MACHINE FOR POUNCING HATS.

SPECIFICATION forming part of Letters Patent No. 480,098, dated August 2, 1892.

Application filed May 7, 1891. Serial No. 391,892. (No model.)

*To all whom it may concern:*

Be it known that I, JOHN B. HOWE, a citizen of the United States, residing at Danbury, in the county of Fairfield and State of Connecticut, have invented certain new and useful Improvements in Hat-Pouncing Machines; and I do hereby declare the following to be a full, clear, and exact description of the invention, such as will enable others skilled in the art to which it appertains to make and use the same.

This invention relates to certain novel and useful improvements in hat-pouncing machines, and is in some particulars an improvement upon the machine shown and described in certain Letters Patent of the United States, No. 414,415, granted to me the 5th day of November, 1889.

The objects of my present invention are, first, to provide for the automatic movement of the pouncer over the hat-crown, so as to pounce its entire surface, the pouncer-face being held thereon throughout the operation with an unvarying pressure; second, to provide a flexible driving connection for the pouncer, so that some freedom of movement may be accorded to the latter; third, to provide means for automatically removing the pouncer out of contact with the hat at the end of the pouncing operation and to throw off at or about the same time the feeding mechanism; fourth, to furnish clutch mechanism for varying the speed of the lathe and for throwing off and on the pouncer-driving gear, and, fifth, and in general, to provide a machine which shall be simple in construction and rapid and automatic in its operation; and with these ends in view my invention consists in the construction and combination of elements hereinafter fully explained, and then recited in the claims.

In order that those skilled in the art to which my invention appertains may fully understand its construction and method of operation, I will describe the same in detail, reference being had to the accompanying drawings and the numerals marked thereon, which form a part of this specification.

The same numerals denote the same parts in each of the figures.

Figure 1 is a side elevation of my machine; Fig. 2, a plan view with the parts in the same

position--namely, ready to commence the pouncing operation; Fig. 3, a similar view, showing the same parts at the completion of the pouncing operation; Fig. 4, a vertical section through the lathe; Fig. 5, a section at the line  $xx$  of Fig. 3, looking in the direction of the arrow; Fig. 6, a like section at the line  $yy$  of Fig. 3; Fig. 7, a section at the line  $ww$  of Fig. 6; Fig. 8, a vertical section through the pouncer-head, showing the sandpaper in position; Fig. 9, a similar section at right angles to Fig. 8; Fig. 10, a plan view of the pouncer-handle; Fig. 11, a detail perspective of the stem 60 and the jaws 56, and Fig. 12 a detail plan view of the parts shown at Fig. 9.

Referring more particularly to Figs. 1, 2, and 3, 1 designates the frame, which may be of any shape or construction suitable to support the several moving parts and their connections. The main shaft 2, upon which is a driving band-wheel 3, is journaled longitudinally in the lower portion of the frame. Just within the frame this shaft bears a gear 4, whose function will be presently explained, and upon its end is secured a beveled friction-disk 5.

6 denotes the vertical shaft constituting the spindle of the lathe. (See Fig. 4.) This spindle has a suitable chuck, whereby is carried a hat-block 7, and between the spindle and said hat-block, within the casing denoted by the numeral 8, is interposed mechanism for imparting a gyrating motion to the block; but the chuck and this mechanism form no part of my present invention, being described in the Letters Patent heretofore referred to, and particularly shown in Fig. 14 of the drawings of said patent.

9 is a sleeve secured upon the shaft 6 by means of a pin 10 or other suitable fastening. The upper end of this sleeve bears a small abutment-flange. (Shown at Fig. 4.) Around this sleeve 9 and splined thereto, as shown at 11, is a hub 12, having a beveled friction-wheel 13 secured near its lower portion and a tapered clutch-face 14 upon its upper end. Above the clutch-face 14 a sleeve 15 surrounds the shaft 6. Upon its lower end said sleeve bears a band-pulley 16, having tapered clutch-faces 17 and 18, one above the center of the band-wheel and the other below it. The clutch-face 18 may be caused to engage with the

clutch-face 14, and the clutch-face 17 may also be caused to engage with a tapered clutch-face 19 upon a band-wheel 20, which latter has its journal-bearing around the upper portion of the sleeve 15. These clutches, of which there are two, as will be readily observed, are operated by means of a pair of horizontally-disposed levers 21 and 22, whose inner ends are pivoted to a vertical rod or standard 23 and which near their centers are split and engage the former with the hub 12 and the latter with the band-wheel 20. The outer ends of these levers 21 and 22 are secured to a vertical rod 24, having a suitable handle, and engaging at its lower end with an incline or cam-surface 25, upon which it may ride when turned in its bearings by means of the handle. Before describing the operation of these clutches it is necessary to mention certain co-operating parts to which they are connected. The gear 4 on the main shaft by a companion gear drives a vertical shaft 26, which bears a band-wheel 27 in substantially the same horizontal plane with the band-wheel 16, to which it is connected by a belt 28. A belt 29 runs on the band-wheel 20 and serves to drive a vertical shaft 30, adapted to communicate motion to the pouncer-head, as will presently be set forth.

It is desired in a hat-pouncing machine to impart to the hat-block two speeds—one for rotating the hat beneath the pouncer and the other for greasing the surface of the hat after pouncing operation has been completed. The pouncing speed should be much less than the greasing speed, and in my present machine I have arranged for these two speeds, and also arranged to throw off the pouncer, so that it may remain idle during the greasing operation.

In Fig. 4 the parts are shown in position, deriving the proper speed for pouncing the hat. The shaft 6 is driven direct from the two beveled friction-wheels at about sixty turns a minute. The clutch-face 14, it will be observed, is not engaged with the face 18, therefore no connection exists between the hub 12 and the band-wheel 16. This band-wheel 16 is at all times driven at high speed off the vertical shaft 26 by means of the belt 28, and as the clutch-surfaces 17 and 18 are in engagement it is carrying the band-wheel 20 with it. This in turn, by means of the band 29, drives the pouncer-shaft 30. Now when it is desired to stop the pouncer and rotate the block at the higher speed for the purpose of greasing the hat the rod 24 is turned in its bearings. This lifts the levers 21 and 22, and through them the hub 12 and band-wheel 20. In raising the hub 12 the friction-disk 13 is disengaged from the disk 5, the wheel 20 is disengaged from the wheel 16, and the coned clutch-face 14 is made to engage with the clutch-face 18. Therefore at this time the shaft 6 will be driven by means of the band 28, instead of directly from the shaft 2; but the wheel 16 will no longer drive the wheel

20, which carries the pouncer. A considerable space will be observed between the faces 14 and 18 in Fig. 4. If it is desired to stop both the pouncer and the lathe, as for the purpose of removing a hat, the rod 24 is turned about half of its full movement, whereby the friction-disks 5 and 13 will be disengaged. The clutch-surfaces 17 and 19 will also be disengaged; but the surfaces 14 and 18 will not be engaged. This of course places the several parts in such position that the main shaft cannot drive the vertical shaft 6 direct and the belt 28 is driving the small band-wheel 16 idly about the shaft 6 as an axis.

The upper end of the vertical shaft 26 bears a worm 31, and this engages with and drives a worm-wheel 32, secured upon a short horizontal shaft 33. The outer end of this shaft 33 bears a worm 34, adapted to engage and drive a worm-wheel 35 on a vertical shaft 36. The upper end of this latter vertical shaft bears a beveled gear 37, and this meshes with a companion gear 38 on a short horizontal shaft 39, journaled in a standard 40, mounted upon the bed.

41 is a shaft whose end turns in a bearing centrally formed in the shaft 39, and the shaft 41 bears a toothed clutch-hub 42, adapted to be engaged with or disengaged from the shaft 39, so that, as will hereinafter be explained, said shaft 41 may have an intermittent rocking movement instead of the constant rotary movement which the shaft 39 derives from its driving-gears. The shaft 41 extends horizontally through bearings 43 and 44, which project upward from a standard 45. The outer end of the shaft bears a longitudinally-slotted crank-arm 46 and a cam 47, whose face engages the face of a stationary cam 48 upon the bearing 44. The purpose of these two cams is to automatically withdraw the shaft 41 in its bearings, so as to disengage its clutch-hub from the shaft 39 against the pressure of a spring 49, coiled about said shaft 41 between the outer face of the bearing 43 and a stationary bracket 50, secured upon said shaft. The pouncer arm or lever 51 is fulcrumed at one end to the upper portion of the bracket 50. It extends through the slot in the crank 46, to whose extremity it is connected by means of a spiral spring 52. Said lever 51 has guides 53, through which passes a flexible shaft 54, whose rear end is connected to the shaft 30 and whose forward end drives the pouncer-head. This pouncer-head consists of a tubular body 55, at the end of which is a holder 56, consisting of a pair of jaws. Within the holder is a pad to support the sandpaper, and this I prefer to make of a layer of leather 57, overlaid with a disk of rubber 58, between which and the flange of the holder a layer of sandpaper 59 may be introduced and held.

The holder 56, above referred to, is borne upon the end of a short shaft 60, connected by a pin 61 with the tubular body by means of a slot 62 in the latter. By means of nuts 63 and 64 the movement required to com-

press the sandpaper in the position shown at Fig. 8 is obtained. The pouncer-head is rotated as a whole by means of the flexible shaft 54, and the details of construction just described will be understood by reference to Figs. 8 and 9. The pouncer-handle 65 is mounted upon the end of the lever 51 by means of a set-screw 66. (Shown at Fig. 1.) This joint permits the handle to be moved longitudinally or axially relative to the lever. At its center the handle is cut away, as shown at 67, and within the opening thus formed is swiveled a ring 68, adapted to surround the neck of the pouncer-head. This ring may be permitted to move upon its journals, or it may be held as against such movement by a binding-screw 69, passed through the longitudinally-slotted portion of the handle, as shown in detail at Fig. 10.

I will now describe that portion of my machine by which the movement required to carry the pouncer over the whole surface of the hat-crown is derived and the pouncer removed out of contact after its function has been performed. Between the bearings 43 and 44 the shaft 41 bears a gear 70, to which is affixed a double-faced strap-wheel 71. This compound part is journaled around the shaft and is not connected to it.

72 is a strap, one end of which is secured to and adapted to be wound upon one face of the strap-wheel, and 73 is another strap similarly connected to the other face. The strap 72 carries a weight 74, hung upon its lower end, and the strap 73 has its extremity secured to an eye or ring upon the pouncer-lever 51. Parallel with the shaft 41 and in the same horizontal plane is journaled a shaft 75, having its bearings in standards 76 and 40. At its outer end it is provided with a cranked handle 77. Fast upon this shaft and projecting outwardly therefrom is secured a weight 78, adapted, as hereinafter provided, to rotate said shaft in its bearings. Referring now particularly to Figs. 6 and 7, 79 is a gear journaled about the shaft 75. Its larger face is recessed, and within said recess and secured upon the shaft is a disk 80, having its periphery cut away, as shown at Fig. 6. In this peripheral slot runs a pin 81, projecting from the face of the gear.

82 is a disk (shown in face view at Fig. 5) secured upon the shaft 75. It is provided with two notches 83 and 84 in its periphery, and these are adapted to be engaged by the hooked extremity of the lever 85, which is journaled around the shaft 41 and whose outer end is supported by a spring 86, surrounding a pin 87 in such manner that said lever may be depressed against the action of the spring sufficiently to disengage the hook just referred to, and which is numbered 88, from the notch in the periphery of the disk.

The method of operation of my machine when organized as above described is as follows: The pouncer-lever 51, as will be observed, has a movement upon its fulcrum con-

nection with the bracket 50, and said bracket has at times a movement with the shaft 41. In commencing the pouncing operation the lever is carried to the position shown at Figs. 1 and 2, so that the abrasive-surface of the pouncer-head rests upon the crown of the hat. It will be observed that the spring 52 is interposed between the end of the crank 46 and an eye or ring on the lever 51. The draft of this spring has a tendency to raise said lever; but its strength is insufficient to move it when the parts are in the position shown at Figs. 1 and 2. The pressure of the pouncer-face upon the hat-crown is derived from the weight 74, which by means of its strap tends to rotate the part 71, which in turn, through the strap 73, draws upon the lever. When the parts are thus in engagement, the driving-gear appropriate to impart to the hat the pouncing speed is thrown in, so that the chuck is driven through the friction-disks 13 and 5 and the flexible shaft 54 caused to rotate at high speed by means of the pulleys 27, 16, and 20 and the driving-bands 28 and 29. The rate of rotation of the pouncer-head may be five hundred turns a minute, more or less. At this time the clutch-hub 42 on the shaft 41 is in engagement with the clutch-face on the short shaft 39, so that the latter, which derives a very slow rotation through the connection which it has with the vertical shaft 26, will turn the shaft 41 in its bearings. Owing to the passage of the lever 51 through the slotted crank 46, this movement will carry the pouncer-head slowly downward over the rotating crown of the hat, whose surface is suitably ground or pounced. This movement continues until the edge of the pouncer comes in contact with the brim of the hat. At the time of placing the pouncer in the position shown at Fig. 1 the rock-shaft 75, by means of its crank 77, is turned to the position shown at Fig. 1—that is, with the crank vertical and the weight 78 standing at an angle somewhat above the horizontal. In this position it is held by the engagement of the hooked end of the lever 88 engaging with the notch 84. This engagement is maintained by the upward pressure of the spring 86, as is shown at Fig. 5. During the downward passage of the pouncer-head heretofore set forth its engagement with the hat-crown is maintained by the weight 74, which, through the strap 73, first draws the lever downward and then inward. When the pouncer has nearly completed its movement, the lever 51 comes in contact with the outer end of the lever 85, and this lifts the hook out of engagement with the notch 84. This releases the weight which falls, and, through the engagement of the disk 80 with the pin 81 on the gear 79, rotates the latter a portion of a revolution. This movement of the gear 79 rotates the gear 70 and the strap-wheels secured thereto in such manner as to lift the weight 74 and slack off the tension on the strap 73. As the strain upon this strap is relaxed the spring 52 withdraws the lever

51 outward in the slotted crank to substantially the position shown at Fig. 3, with its face removed from the hat-crown. The cams 47 and 48 are so timed that at the time of the release of the lever 51 their highest points come in conjunction, and this withdraws the clutch-face 42 out of engagement with the shaft 39, and thereby prevents any further feeding movement of the shaft 41. It is then advantageous to change the speed of the hat-block for the purpose of greasing the hat and at the same time stop the pouncer. This is done by raising the clutch-levers 21 and 22 by turning the operating-handle, whereby, as heretofore set forth, the friction-disks 13 and 5 are disengaged, the wheel 20 rendered idle, and the shaft 6 caused to be driven by the band-wheel 16 through the engagement of its clutch-face with the co-operating face on the hub 12. After the greasing operation the parts are restored to their starting position by hand—that is, the lever 51 is carried upward, so as to rest upon the top of the hat, which movement disengages the high points of the cams 47 48 and permits the clutches on the parts 39 and 42 to re-engage and the shaft 75 is restored to the position shown at Fig. 1, where it is held with the weight 78 raised by the engagement of the hook 88 until again stripped by the next descent of the pouncer-lever.

In this my invention I do not wish to be confined to the precise details of construction which I have herein shown and described, since the parts and their connection may be varied in many respects without either changing the general mode of operation of my machine or departing from the essentials of my invention which I deem to be commensurate in scope with the terms of the clauses of claims here following.

In this application I have shown a construction of pouncer-head as operating in connection with the other parts of the machine; but I make no claim thereto herein, since a similar construction is shown and described and claimed in a certain pending application, Serial No. 423,519, filed by me March 2, 1892.

I claim—

1. In a hat-pouncing machine, the combination, with the rotative hat-support, of the pouncer-lever, the pouncer connected therewith, a weight and connections interposed between it and the pouncer-lever, whereby the pouncer is forced against the hat, the notched disk and the hook engaging therewith, the gears 79 and 70, and means, as described, for disengaging the hook from the disk, the whole arranged and adapted to operate substantially as set forth.

2. The combination, with the pouncer-lever and the shaft whereby it is carried, of a clutch interposed between said shaft and a constantly-moving part of the machine, a spring for normally holding the shaft in engagement, and a pair of cams whereby the

disengagement of the clutch is effected and the shaft stopped, substantially as and for the purpose set forth.

3. The combination, with the pouncer-lever having accommodation for a pouncer-head, of the feeding shaft 41, a clutch for connecting said shaft to a constantly-moving portion of the machine, cams, as described, for disengaging said clutch, and a slotted crank embracing the pouncer-lever, whereby said lever will be moved over the surface of the hat, but may be thrown outward in the slot for purposes of disengagement.

4. The combination, with the pouncer-lever of the feeding-shaft 41, the clutch whereby said shaft is connected with its motor part, the spring for engaging the clutch, the means for disengaging the clutch, the slotted crank carried by said shaft, the strap and weight mechanism for drawing the pouncer-head against the hat, and the spring for disengaging it therefrom, substantially as described.

5. The combination, with the pouncer-lever having a seat for the pouncer-head, of the bracket to which said lever is fulcrumed, the shaft to which the bracket is attached, means for starting and stopping the shaft, a slotted crank whereby the lever is carried with the shaft, a weight and strap for insuring the engagement of the pouncer, and a spring for effecting the disengagement of the pouncer, substantially as described.

6. The combination, with the pouncer-lever and the pouncer-head seated and adapted to revolve in said lever, of the feeding-shaft whereby said pouncer-lever is carried over the surface of the hat, the flexible shaft connected to and adapted to drive the pouncer-head, and driving means, as described, for the rotation of the flexible shaft, substantially as set forth.

7. The combination, with the pouncer-lever, its pouncer, and the feeding-shaft 41, of the double strap-wheel having the connected gear journaled on the feed-shaft, the straps and weights connected to the pouncer-lever, the rock-shaft 75, a disk 80, secured thereto, and a pin 81, secured to a gear connecting with the gear of the feed-shaft, and a weight borne by the shaft 75 and adapted to rotate the same, substantially as set forth.

8. The combination, with the feeding-shaft, the strap-wheels and gear journaled thereon, and the straps and weight, of the rock-shaft journaled behind the feed-shaft and bearing the weight, the gear on said rock-shaft and engaging the gear on the feed-shaft, and the notched disk and the hooked lever engaging the latter, whereby the weight is held in its lifted position, and means for disengaging the rear shaft to permit the weight to act, substantially as specified.

9. The combination, with the hat-support, of the pouncer-head, the pouncer-lever, a handle connected to the end of the latter, said handle having a cut-out portion 67 to receive a swinging ring 68 and having a bearing for

the pouncer-head, and a binding-screw 69 to clamp said ring in its desired position, substantially as described.

5 10. The combination, with the lathe-shaft, of the friction-disk and its hub splined to the lathe-shaft and provided with a clutch, the pulley 16, having two clutch-faces and journaled upon the lathe-shaft, a pulley 20, journaled above the pulley 16 and provided with a clutch-face, and levers connected to the disk-hub and the pulley 20, whereby engagement and disengagement of the several clutch-faces are effected, substantially in the manner hereinbefore specified.

15 11. The disk 13 upon the hub 12, splined to

the lathe-shaft, and the pulley 20, adapted to drive the pouncer, in combination with levers whereby said parts 12 and 20 may be raised relative to the lathe-shaft, and an intermediate pulley journaled about the lathe-shaft 20 and adapted for engagement either with the pulley 20 or the hub 12, substantially as set forth.

In testimony whereof I affix my signature in presence of two witnesses.

JOHN B. HOWE.

Witnesses:

SHERMAN HARTWELL HUBBARD,

M. C. HINCHCLIFFE.